

KINCROME **PT**

Angle Grinder 125mm 900W

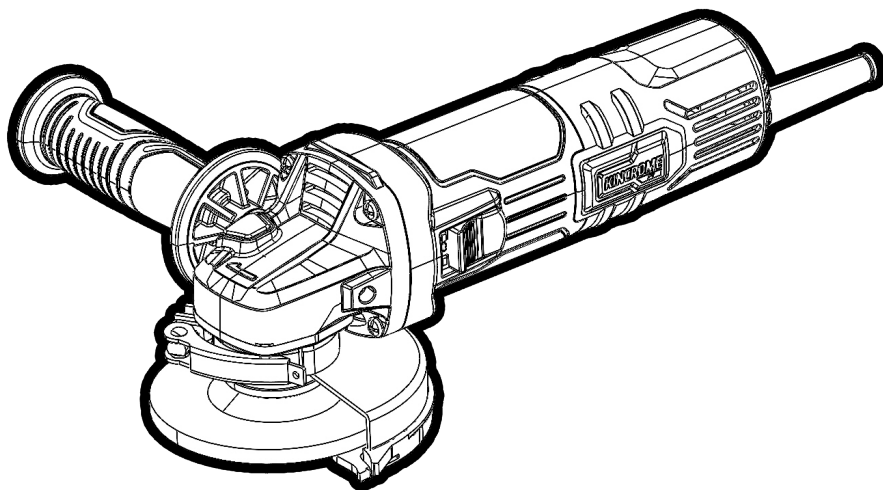

K23220

ED2 December 2023

General Power Tool Safety Warnings

K23220



WARNING Read all safety warnings and all instructions. Failure to follow the warnings and instructions may result in electric shock, fire and/or serious injury. Save all warnings and instructions for future reference. The term "power tool" in the warnings refers to your mains-operated (corded) power tool or battery-operated (cordless) power tool.

1) Work area safety

- a) **Keep work area clean and well lit.** Cluttered or dark areas invite accidents.
- b) **Do not operate power tools in explosive atmospheres, such as in the presence of flammable liquids, gases or dust.** Power tools create sparks which may ignite the dust or fumes.
- c) **Keep children and bystanders away while operating a power tool.** Distractions can cause you to lose control.

2) Electrical safety

- a) **Power tool plugs must match the outlet. Never modify the plug in any way. Do not use any adapter plugs with earthed (grounded) power tools.** Unmodified plugs and matching outlets will reduce risk of electric shock.
- b) **Avoid body contact with earthed or grounded surfaces, such as pipes, radiators, ranges and refrigerators.** There is an increased risk of electric shock if your body is earthed or grounded.
- c) **Do not expose power tools to rain or wet conditions.** Water entering a power tool will increase the risk of electric shock.
- d) **Do not abuse the cord. Never use the cord for carrying, pulling or unplugging the power tool. Keep cord away from heat, oil, sharp edges or moving parts. Damaged or entangled cords increase the risk of electric shock.**
- e) **When operating a power tool outdoors, use an extension cord suitable for outdoor use.** Use of a cord suitable for outdoor use reduces the risk of electric shock.
- f) **If operating a power tool in a damp location is unavoidable, use a residual current device (RCD) protected supply. Use of an RCD reduces the risk of electric shock.**

3) Personal safety

- a) **Stay alert, watch what you are doing and use common sense when operating a power tool. Do not use a power tool while you are tired or under the influence of drugs, alcohol or medication.** A moment of inattention while operating power tools may result in serious personal injury.
- b) **Use personal protective equipment. Always wear eye protection.** Protective equipment such as dust mask, non-skid safety shoes, hard hat, or hearing protection used for appropriate conditions will reduce personal injuries.
- c) **Prevent unintentional starting. Ensure the switch is in the off-position before connecting to power source and/or battery pack, picking up or carrying the tool.** Carrying power tools with your finger on the switch or energising power tools that have the switch on invites accidents.
- d) **Remove any adjusting key or wrench before turning the power tool on.** A wrench or a key left attached to a rotating part of the power tool may result in personal injury.
- e) **Do not overreach. Keep proper footing and balance at all times.** This enables better control of the power tool in unexpected situations.
- f) **Dress properly. Do not wear loose clothing or jewellery. Keep your hair, clothing and gloves away from moving**

parts. Loose clothes, jewellery or long hair can be caught in moving parts.

- g) **If devices are provided for the connection of dust extraction and collection facilities, ensure these are connected and properly used.** Use of dust collection can reduce dust-related hazards.
 - h) **Do not let familiarity gained from frequent use of tools allow you to become complacent and ignore tool safety principles.** A careless action can cause severe injury within a fraction of a second.
- ### 4) Power tool use and care
- a) **Do not force the power tool. Use the correct power tool for your application.** The correct power tool will do the job better and safer at the rate for which it was designed.
 - b) **Do not use the power tool if the switch does not turn it on and off.** Any power tool that cannot be controlled with the switch is dangerous and must be repaired.
 - c) **Disconnect the plug from the power source and/or the battery pack from the power tool before making any adjustments, changing accessories, or storing power tools.** Such preventive safety measures reduce the risk of starting the power tool accidentally.
 - d) **Store idle power tools out of the reach of children and do not allow persons unfamiliar with the power tool or these instructions to operate the power tool.** Power tools are dangerous in the hands of untrained users.
 - e) **Maintain power tools. Check for misalignment or binding of moving parts, breakage of parts and any other condition that may affect the power tool's operation.** If damaged, have the power tool repaired before use. Many accidents are caused by poorly maintained power tools.
 - f) **Keep cutting tools sharp and clean.** Properly maintained cutting tools with sharp cutting edges are less likely to bind and are easier to control.
 - g) **Use the power tool, accessories and tool bits etc. in accordance with these instructions, taking into account the working conditions and the work to be performed.** Use of the power tool for operations different from those intended could result in a hazardous situation.
 - h) **Keep handles and grasping surfaces dry, clean and free from oil and grease.** Slippery handles and grasping surfaces do not allow for safe handling and control of the tool in unexpected situations.
- ### 5) Service
- a) **Have your power tool serviced by a qualified repair person using only identical replacement parts.** This will ensure that the safety of the power tool is maintained.

Safety instructions for Cutting & Grinding

Safety warnings common for grinding or cutting-off operations:

- a) **This power tool is intended to function as a grinder or cut-off tool. Read all safety warnings, instructions, illustrations and specifications provided with this power tool.** Failure to follow all instructions listed below may result in electric shock, fire and/or serious injury.
- b) **Operations such as sanding, wire brushing, polishing, hole cutting are not to be performed with this power tool.** Operations for which the power tool was not designed may

K23220

- create a hazard and cause personal injury.*
- c) **Do not convert this power tool to operate in a way which is not specifically designed and specified by the tool manufacturer.** *Such a conversion may result in a loss of control and cause serious personal injury.*
 - d) **Do not use accessories which are not specifically designed and specified by the tool manufacturer.** *Just because the accessory can be attached to your power tool, it does not assure safe operation.*
 - e) **The rated speed of the accessory must be at least equal to the maximum speed marked on the power tool.** *Accessories running faster than their rated speed can break and fly apart.*
 - f) **The outside diameter and the thickness of your accessory must be within the capacity rating of your power tool.** *Incorrectly sized accessories cannot be adequately guarded or controlled.*
 - g) **The dimensions of the accessory mounting must fit the dimensions of the mounting hardware of the power tool.** *Accessories that do not match the mounting hardware of the power tool will run out of balance, vibrate excessively and may cause loss of control.*
 - h) **Do not use a damaged accessory. Before each use inspect the accessory such as abrasive wheels for chips and cracks, backing pad for cracks, tear or excess wear, wire brush for loose or cracked wires. If power tool or accessory is dropped, inspect for damage or install an undamaged accessory. After inspecting and installing an accessory, position yourself and bystanders away from the plane of the rotating accessory and run the power tool at maximum no-load speed for one minute. Damaged accessories will normally break apart during this test time.**
 - i) **Wear personal protective equipment.** Depending on application, use face shield, safety goggles or safety glasses. As appropriate, wear dust mask, hearing protectors, gloves and workshop apron capable of stopping small abrasive or workpiece fragments. *The eye protection must be capable of stopping flying debris generated by various applications. The dust mask or respirator must be capable of filtering particles generated by the particular application. Prolonged exposure to high intensity noise may cause hearing loss.*
 - j) **Keep bystanders a safe distance away from work area. Anyone entering the work area must wear personal protective equipment.** *Fragments of workpiece or of a broken accessory may fly away and cause injury beyond immediate area of operation.*
 - k) **Hold the power tool by insulated gripping surfaces only, when performing an operation where the cutting accessory may contact hidden wiring or its own cord.** *Cutting accessory contacting a "live" wire may make exposed metal parts of the power tool "live" and could give the operator an electric shock.*
 - l) **Position the cord clear of the spinning accessory.** *If you lose control, the cord may be cut or snagged and your hand or arm may be pulled into the spinning accessory.*
 - m) **Never lay the power tool down until the accessory has come to a complete stop.** *The spinning accessory may grab the surface and pull the power tool out of your control.*
 - n) **Do not run the power tool while carrying it at your side.** *Accidental contact with the spinning accessory could snag*

- your clothing, pulling the accessory into your body.*
- o) **Regularly clean the power tool's air vents.** *The motor's fan will draw the dust inside the housing and excessive accumulation of powdered metal may cause electrical hazards.*
- p) **Do not operate the power tool near flammable materials.** *Sparks could ignite these materials.*

Further safety instructions for all operations Kickback and related warnings

Kickback is a sudden reaction to a pinched or snagged rotating wheel, backing pad, brush or any other accessory. Pinching or snagging causes rapid stalling of the rotating accessory which in turn causes the uncontrolled power tool to be forced in the direction opposite of the accessory's rotation at the point of the binding.

For example, if an abrasive wheel is snagged or pinched by the workpiece, the edge of the wheel that is entering into the pinch point can dig into the surface of the material causing the wheel to climb out or kick out. The wheel may either jump toward or away from the operator, depending on direction of the wheel's movement at the point of pinching. Abrasive wheels may also break under these conditions.

Kickback is the result of power tool misuse and/or incorrect operating procedures or conditions and can be avoided by taking proper precautions as given below.

- a) **Maintain a firm grip with both hands on the power tool and position your body and arms to allow you to resist kickback forces.** *Always use auxiliary handle, if provided, for maximum control over kickback or torque reaction during start-up. The operator can control torque reactions or kickback forces, if proper precautions are taken.*
- b) **Never place your hand near the rotating accessory** *Accessory may kickback over your hand.*
- c) **Do not position your body in the area where power tool will move if kickback occurs.** *Kickback will propel the tool in direction opposite to the wheel's movement at the point of snagging.*
- d) **Use special care when working corners, sharp edges, etc. Avoid bouncing and snagging the accessory.** *Corners, sharp edges or bouncing have a tendency to snag the rotating accessory and cause loss of control or kickback.*
- e) **Do not attach a saw chain woodcarving blade, segmented diamond wheel with a peripheral gap greater than 10 mm or toothed saw blade.** *Such blades create frequent kickback and loss of control.*

Additional safety instructions for grinding and cutting-off operations

Safety warnings specific for grinding and cutting-off operations:

- a) Use only wheel types that are specified for your power tool and the specific guard designed for the selected wheel. *Wheels for which the power tool was not designed cannot be adequately guarded and are unsafe.*
- b) The grinding surface of centre depressed wheels must be mounted below the plane of the guard lip. *An improperly mounted wheel that projects through the plane of the guard lip cannot be adequately protected.*
- c) The guard must be securely attached to the power tool and positioned for maximum safety, so the least amount of wheel is exposed towards the operator. *The guard helps to protect the operator from broken wheel fragments, accidental contact with wheel and sparks that could ignite clothing.*
- d) Wheels must be used only for specified applications. **For example: do not grind with the side of cut-off wheel.** *Abrasive cut-off wheels are intended for peripheral grinding, side forces applied to these wheels may cause them to shatter.*
- e) Always use undamaged wheel flanges that are of correct size and shape for your selected wheel. *Proper wheel flanges support the wheel thus reducing the possibility of wheel breakage. Flanges for cut-off wheels may be different from grinding wheel flanges.*
- f) Do not use worn down wheels from larger power tools. *A wheel intended for larger power tool is not suitable for the higher speed of a smaller tool and may burst.*
- g) When using dual purpose wheels always use the correct guard for the application being performed. *Failure to use the correct guard may not provide the desired level of guarding, which could lead to serious injury.*











Additional safety instructions for cutting-off operations

Additional safety warnings specific for cutting-off operations:

- a) Do not "jam" the cut-off wheel or apply excessive pressure. **Do not attempt to make an excessive depth of cut.** *Overstressing the wheel increases the loading and susceptibility to twisting or binding of the wheel in the cut and the possibility of kickback or wheel breakage.*
- b) Do not position your body in line with and behind the rotating wheel. *When the wheel, at the point of operation, is moving away from your body, the possible kickback may propel the spinning wheel and the power tool directly at you.*
- c) When the wheel is binding or when interrupting a cut for any reason, switch off the power tool and hold it motionless until the wheel comes to a complete stop. **Never attempt to remove the cut-off wheel from the cut while the wheel is in motion otherwise kickback may occur.** *Investigate and take corrective action to eliminate the cause of wheel binding.*
- d) Do not restart the cutting operation in the workpiece. **Let the wheel reach full speed and carefully re-enter the cut.** *The wheel may bind, walk up or kickback if the power tool is restarted in the workpiece.*
- e) Support panels or any oversized workpiece to minimize the risk of wheel pinching and kickback. *Large workpieces tend to sag under their own weight. Supports must be placed under the workpiece near the line of cut and near the edge of the workpiece on both sides of the wheel.*
- f) Use extra caution when making a "pocket cut" into existing walls or other blind areas. *The protruding wheel may cut gas or water pipes, electrical wiring or objects that can cause kickback.*
- g) Do not attempt to do curved cutting. *Overstressing the wheel increases the loading and susceptibility to twisting or binding of the wheel in the cut and the possibility of kickback or wheel breakage, which can lead to serious injury.*

Symbols

The rating plate on your tool may show symbols. These represent important information about the product or instructions on its use.

	AC Current		Waste electrical products should not be disposed of with household waste. Please recycle where facilities exist. Check with your Local Authority or retailer for recycling advice.
	Refer to instruction manual/booklet		
	Wear ear protection		General warning
	Wear eye protection		Regulator compliance mark
	Wear respiratory protection		Double Insulated product
	Always operate with two hands		

Know Your Product

K23220

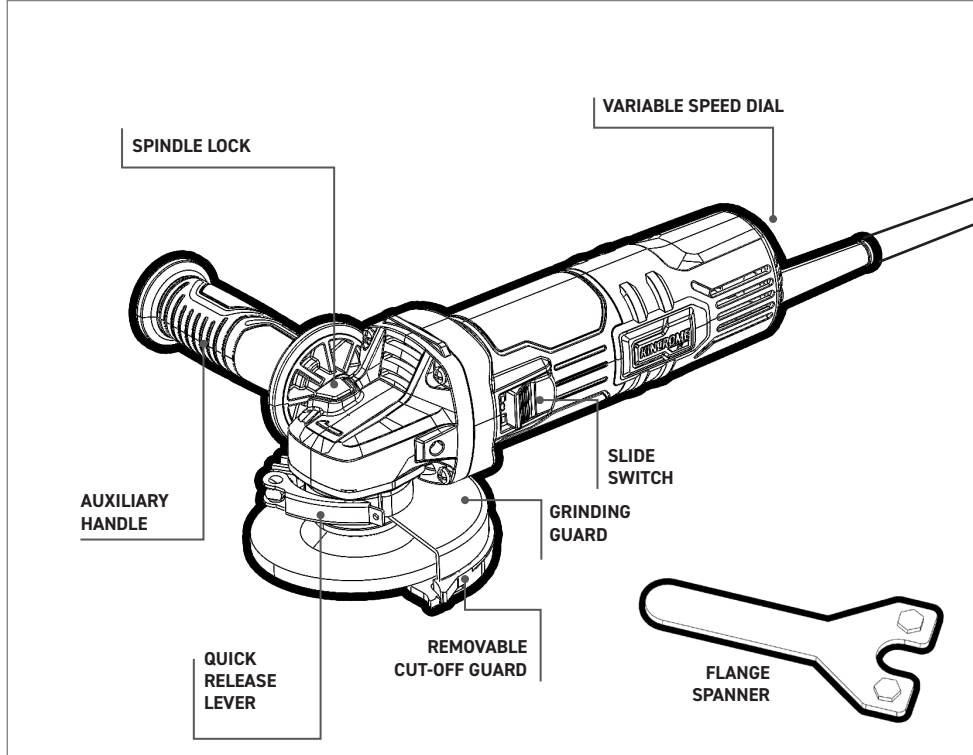

Specifications

Voltage	230-240V~ 50Hz	Max. Disc diameter	125mm (5")
Wattage	900W	Max. Disc Thickness	6mm
No. Load Speed	3,000-11000/min	Weight	2.0kg
Spindle Size	M14		

Assembly - Fitting / Removing the Auxiliary handle



WARNING: Ensure that the side handle is secured but do not over tighten

WARNING: Ensure the tool is switched off and power cord is unplugged before performing any of the following tasks.

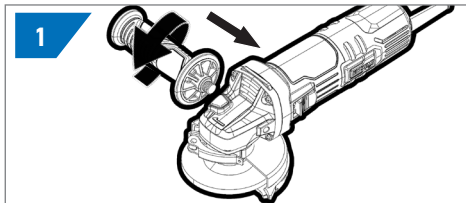

1. TO FIT: SCREW HANDLE INTO GEARBOX ON 1 OF 2 HANDLE POSITIONS

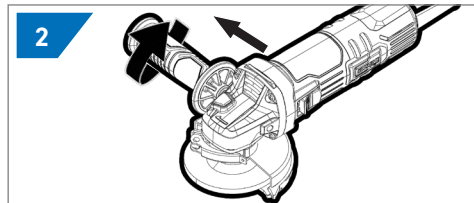

2. TO REMOVE: SCREW THE HANDLE ANTI-CLOCKWISE

Assembly - Grinding Applications

K23220

Fitting the Grinding Guard

 **WARNING:** Ensure the tool is switched off and unplugged before performing any of the following tasks.

The safety guard is pre-fitted to the angle grinder ready for use. The position of the guard can be adjusted following the steps below.

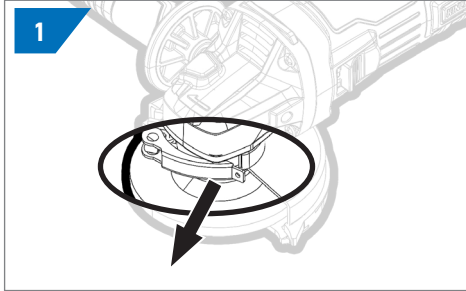

1. RELEASE THE QUICK RELEASE LEVER AND ROTATE GUARD TO DESIRED POSITION.

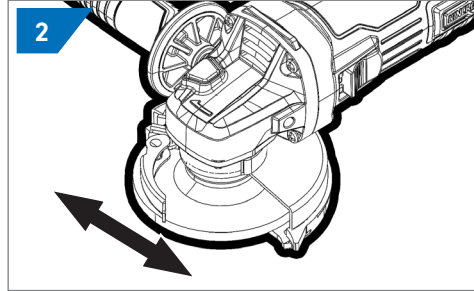

2. DEPRESS QUICK RELEASE LEVER INTO POSITION TO LOCK GUARD INTO PLACE.

Fitting the Grinding Disc

 **WARNING:** Ensure the tool is switched off and unplugged before performing any of the following tasks.
WARNING: Grinding discs can only be used for grinding applications. Use in cutting applications can cause serious injury.

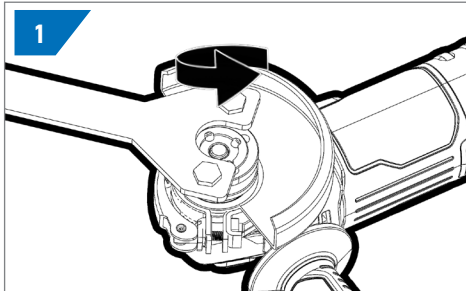

1. HOLD DOWN SPINDLE LOCK AND USE FLANGE SPANNER TO LOOSEN THE OUTER FLANGE BY ROTATING IT ANTI-CLOCKWISE.

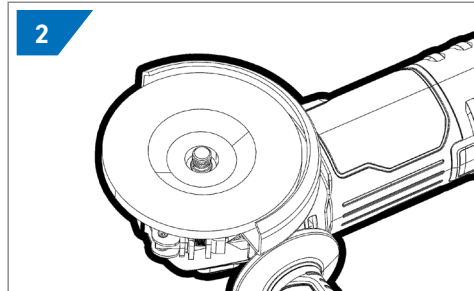

2. REMOVE OUTER FLANGE AND INSERT GRINDING DISC ENSURING IT IS SEATED CORRECTLY ON THE INNER FLANGE.

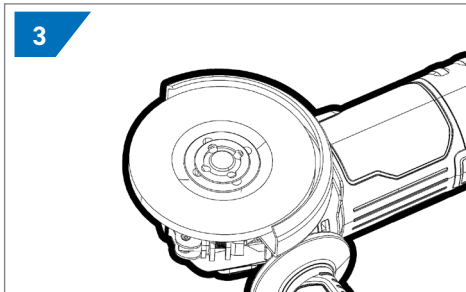

3. PLACE OUTER FLANGE OVER THE GRINDING DISC WITH THE FLAT SIDE FACING AWAY FROM THE DISC.

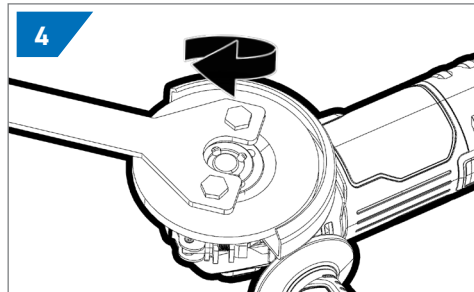

4. HOLD SPINDLE LOCK AND TIGHTEN THE OUTER FLANGE BY ROTATING IT CLOCKWISE. ENSURE DISC IS SECURELY FASTENED.

Assembly - Cutting Applications

K23220

Fitting the Cutting Guard



WARNING: Ensure the tool is switched off and unplugged before performing any of the following tasks.

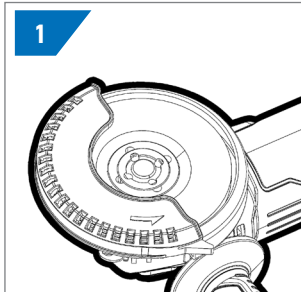

1. ALIGN CUTTING GUARD GROOVE WITH LIP OF GRINDING GUARD.

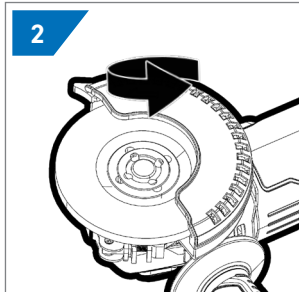

2. FIRMLY ROTATE GUARD UNTIL LOCKS INTO PLACE.

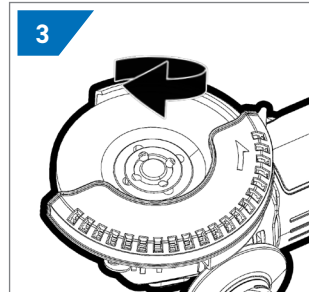

3. TO REMOVE PUSH RELEASE TAB ON CUTTING GUARD, ROTATE AND REMOVE FROM GRINDING GUARD.

Fitting the Cutting Disc



WARNING: Ensure the tool is switched off and unplugged before performing any of the following tasks.

WARNING: Cutting discs can only be used for cutting applications. Use in grinding applications can cause serious injury.

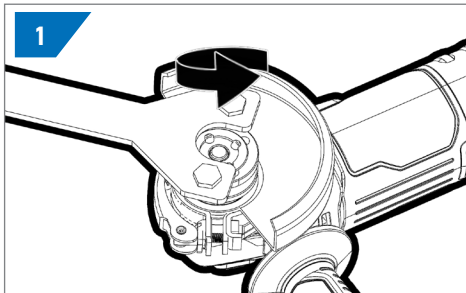

1. HOLD DOWN SPINDLE LOCK AND USE FLANGE SPANNER TO LOOSEN THE OUTER FLANGE BY ROTATING IT ANTI-CLOCKWISE.

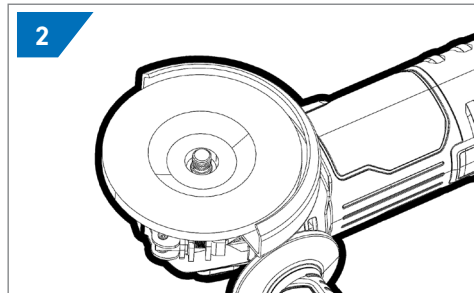

2. REMOVE OUTER FLANGE AND INSERT CUTTING DISK ENSURING IT IS SEATED CORRECTLY ON THE INNER FLANGE.

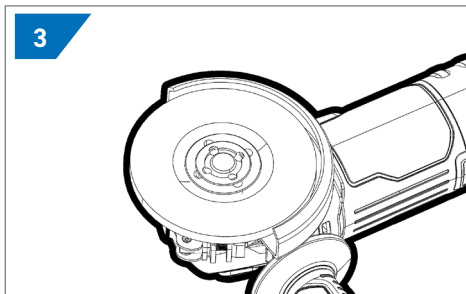

3. PLACE OUTER FLANGE OVER THE CUTTING DISK WITH THE FLAT SIDE FACING TOWARDS THE DISC.

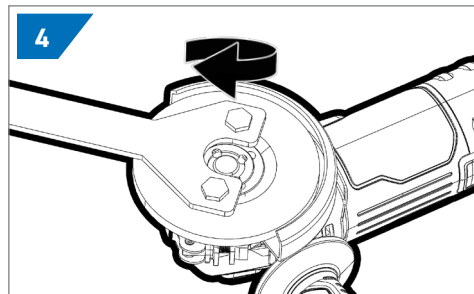

4. HOLD SPINDLE LOCK AND TIGHTEN THE OUTER FLANGE BY ROTATING IT CLOCKWISE. ENSURE DISC IS SECURELY FASTENED. THEN FIT CUTTING GUARD.

Operation

K23220

Turning on the Angle Grinder



WARNING: The tool will not restart automatically if stalled or power outage

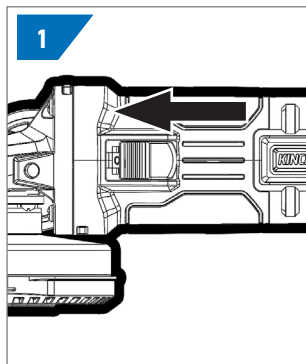

1. TO TURN ON, SLIDE THE LOCK-ON SWITCH TOWARDS THE FRONT OF THE ANGLE GRINDER.

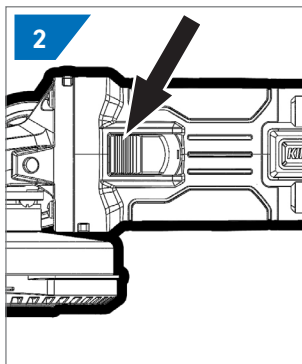

2. TO LOCK-ON, ONCE THE ANGLE GRINDER IS TURNED ON, PUSH THE FRONT DOWN, THEN RELEASE SWITCH TO MAINTAIN LOCK-ON.

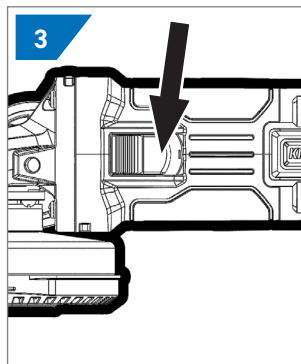

3. TO TURN OFF, PRESS THE BACK OF THE SWITCH AND RELEASE.

Variable Speed

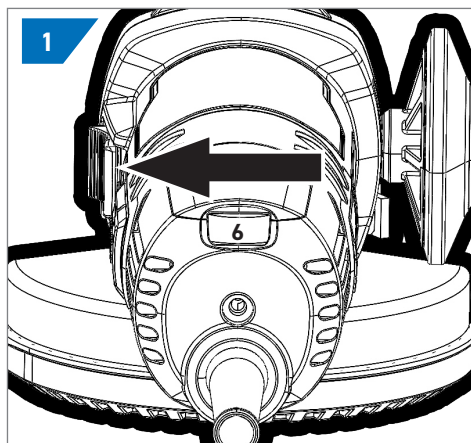

1. TO INCREASE THE SPEED ROTATE THE VARIABLE SPEED DIAL AS SHOWN ABOVE TO A HIGHER NUMBER.

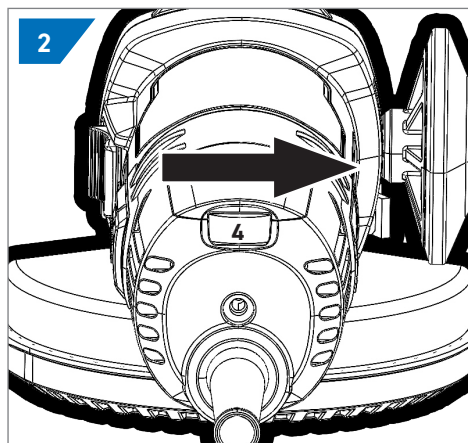

2. TO LOWER THE SPEED ROTATE THE VARIABLE SPEED DIAL AS SHOWN ABOVE TO A LOWER NUMBER.

Grinding

K23220

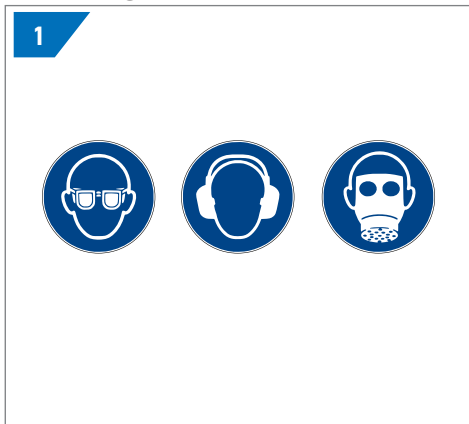

1. ENSURE SAFETY

Always wear safety glasses when working with the angle grinder. Make sure to secure your hair and any baggy clothes. In appropriate situations make sure you wear ear muffs, a mask or a respiratory mask.

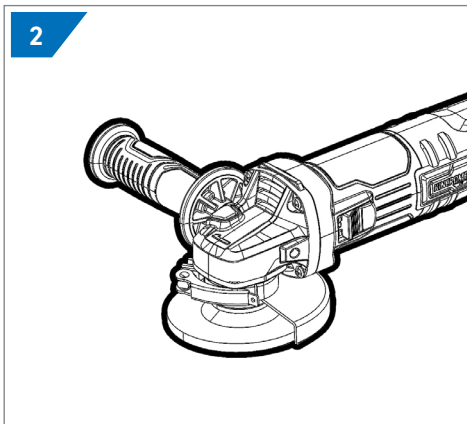

2. MAKE SURE YOU HAVE THE RIGHT GUARD AND DISC FITTED

Use only wheel types that are recommended for your angle grinder and the specific guard designed for the selected wheel.

The guard must be securely attached to the angle grinder and positioned for maximum safety, so the least amount of wheel is exposed towards the operator. The guard helps to protect the operator from broken wheel fragments, accidental contact with wheel and sparks that could ignite clothing.

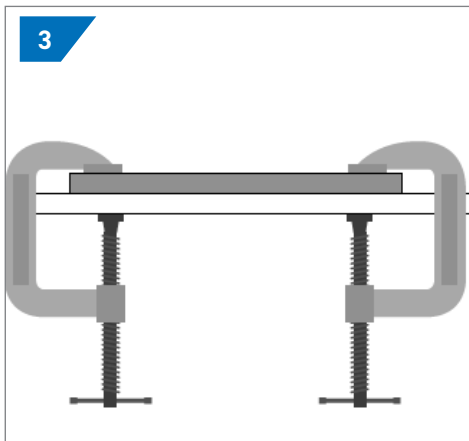

2. SECURE WORKPIECE

Make sure your workpiece is securely fastened to the surface to ensure no movement when grinding.

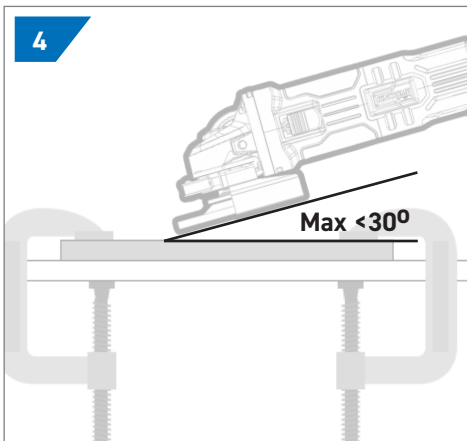

4. GRINDING WORKPIECE

Start with the grinder off the workpiece. Holding the grinder securely, engage the slide switch and slowly move the grinding disc towards where you are intending to grind. Use a back and forth motion to grind your workpiece. The optimum grinding angle is 10-15° to the workpiece. Do not exceed a 30° angle to the workpiece.

Cutting

K23220

1

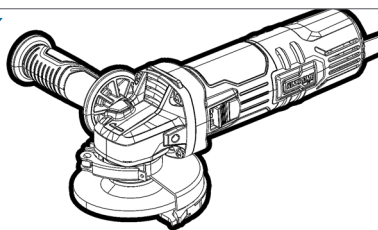

1. ENSURE SAFETY

Always wear safety glasses when working with the angle grinder. Make sure to secure your hair and any baggy clothes. In appropriate situations make sure you wear ear muffs, a mask or a respiratory mask.

2

2. MAKE SURE YOU HAVE THE RIGHT GUARD AND DISC FITTED

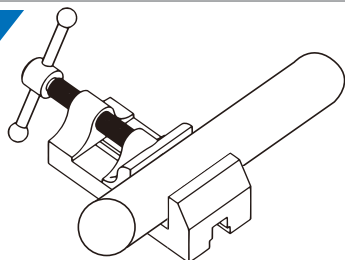
Use only wheel types that are recommended for your angle grinder and the specific guard designed for the selected wheel. The guard must be securely attached to the angle grinder and positioned for maximum safety, so the least amount of wheel is exposed towards the operator. The guard helps to protect the operator from broken wheel fragments, accidental contact with wheel and sparks that could ignite clothing.

3

3. SECURE WORKPIECE

Make sure your workpiece is securely fastened to the surface to ensure no movement when cutting.

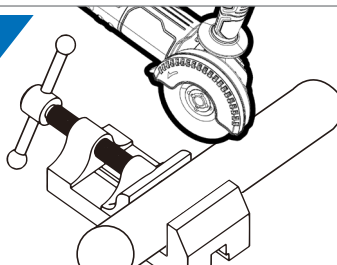
4

4. ENSURE ANGLE GRINDER IS SET UP CORRECTLY

- Do not "jam" the wheel or apply excessive pressure.
- Do not attempt to make an excessive depth of cut. Overstressing the wheel increases the loading and susceptibility to twisting or binding of the wheel in the cut and the possibility of kickback, wheel breakage and overheating of the motor may occur.
- Do not start the cutting operation on the workpiece. Let the wheel reach full speed and carefully enter into the cut moving the tool forward over the workpiece surface. The wheel may bind, walk up or kickback if the power tool is started in the workpiece.
- During cutting operations, never change the angle of the wheel. Placing side pressure on the cut-off wheel (as in grinding) will cause the wheel to crack and break, causing serious personal injury.
- A diamond wheel shall be operated perpendicular to the material being cut. Mount the inner flange onto the spindle. Fit the wheel/disc on the inner flange and screw the lock nut onto the spindle.

Maintenance

K23220

This power tool normally requires no maintenance; from time to time the ventilation slots on the motor casing should be cleaned out. If the unit should become defective, repair should be performed by an authorized service agent for electric tools.

Avoid using solvents when cleaning plastic parts. Most plastics are susceptible to damage from various types of commercial solvents and may be damaged by their use. Use clean cloths to remove dirt, dust, oil, grease, etc.

Warranty does not cover wear and tear components such as brushes.

CARING FOR THE ENVIRONMENT



When a tool is no longer usable it should not be disposed of with household waste, but in an environmentally friendly way. Please recycle where facilities exist. Check with your local council authority for recycling advice. Recycling packaging reduces the need for landfill and raw materials. Reuse of recycled material decreases



pollution in the environment. Please recycle packaging where facilities exist. Check with your local council authority for recycling advice.

SPARE PARTS

For a full list of available spare parts for this item visit the Kincrome website kincrome.com.au or alternatively contact Kincrome Customer Service.

WARNING!

Do not at any time let brake fluids, gasoline, petroleum based products, penetrating oils, etc., come in contact with plastic parts. Chemicals can damage, weaken or destroy plastic which may result in serious personal injury.

OFFICE CONTACT DETAILS



Phone: 1300 657 528



Email: enquiries@kincrome.com.au



Website: www.kincrome.com.au

WARRANTY



3 YEAR STANDARD
+2 FURTHER YEARS WHEN
REGISTERED ONLINE

Our goods and services come with guarantees that cannot be excluded under the Australian Consumer Law. For major failures with the service, you are entitled: -to cancel your service contract with us; and -to a refund for the unused portion, or to compensation for its reduced value. You are also entitled to choose a refund or replacement for major failures with goods. If a failure with the goods or a service does not amount to a major failure, you are entitled to have the failure rectified in a reasonable time. If this is not done you are entitled to a refund for the goods and to cancel the contract for the service and obtain a refund of any unused portion. You are also entitled to be compensated for any other reasonably foreseeable loss or damage from a failure in the goods or service. Kincrome Australia Pty Ltd of 3 Lakeview Drive, Caribbean Park, Scoresby, Victoria (Tel 1300

657 528) also provides the Kincrome Limited Lifetime Guarantee, 5 Year Warranty, 5 Year (3+2) warranty, 3 Year Warranty, 2 Year Warranty and 12-Month Warranty (Kincrome Express Warranties) in respect of some of its products. If a product is covered by a Kincrome Express Warranty and it has materials or workmanship defects (other than defects caused by abnormal or non warranted use) which are covered under the terms of the relevant Kincrome Express Warranty, you can, at your cost, send the product to the above address for repair or replacement. Your rights under a Kincrome Express Warranty are in addition to any other rights you have under the Australian Consumer Law or other applicable laws. For further details and terms please check our product guide, visit www.kincrome.com.au or call us. Every effort is made to ensure advertised stock is available, but due to factors beyond the control of Kincrome Australia Pty. Ltd, not all products advertised in this catalogue may be available at all stores. Kincrome Australia Pty. Ltd. reserves the right to correct printing errors. All sizes shown are approximate only. Accessories shown do not come with the product unless otherwise specified. Due to printing process, colours in this catalogue may vary slightly to actual item. E. & O. E.© Copyright 2022. Reproduction in whole or in part is prohibited without written approval.